

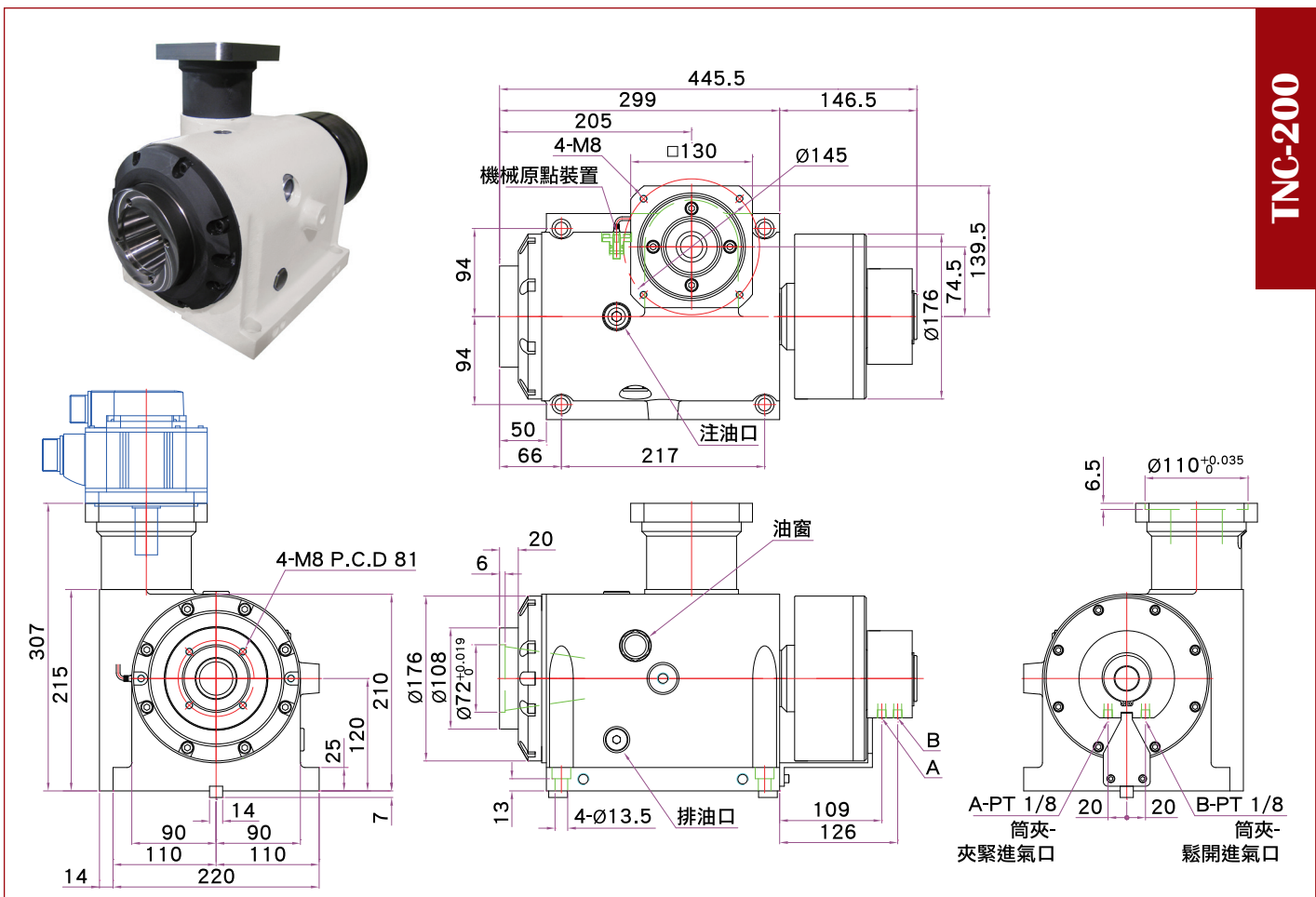



# 刀具研磨機分度頭 Indexing Head

型式 Model		TNC-200	
中心高度 Center height	mm	120	
基準中心孔 Center bore	mm	Ø72 H6	
鎖緊裝置使用壓力 (氣壓) Clamping device (Pneumatic)	kg/cm <sup>2</sup>	5	
鎖緊拉力 (油壓 35kg/cm 時) Clamping force (35kg/cm)	kg	775	
分割精度 (累積值) Indexing accuracy (accumulative)	arc sec	20"	
重現精度 Repeatability	arc sec	4"	
最小分割角度 Min. indexing degree	degree	0.001°	
最高轉度 Max. rotation speed	轉盤 Table	rpm	33.3
	馬達 Motor	rpm	2000
伺服馬達 (選配) Servo motor (optional)	安川 YASKAWA		SGMGV-09
	三菱 MITSUBISHI		HC-SFS52(102)
總齒數比 Gear ratio		1/60	
淨重 (不含主軸及伺服馬達) Net weight (without spindle and motor)	kg	35	



TNC-200

# 搖擺頭旋轉座 Swing Base of Spindle Head

型式 Model		NRS-320		
工作台尺寸 Table size (L x W)	mm	320		
傾斜角度 Tilting range		±120°		
鎖緊裝置 (油壓) Clamping device (Hydraulic)	kg/cm <sup>2</sup>	35		
最小分割角度 Min. indexing degree	degree	0.001°		
分割精度 (累積值) Indexing accuracy (accumulative)	arc sec	15"		
重現精度 Repeatability	arc sec	4"		
鎖緊扭力 Clamping torque	kg-m	180		
最高轉速 Max. rotation speed	轉盤 Table	rpm	16.6	
	馬達 Motor	rpm	2000	
伺服馬達 (選配) Servo motor (optional)	發那科 FANUC		α12i	
	三菱 MITSUBISHI		HF-204 / HF-354	
總齒數比 Gear ratio		1/120		
容許切削扭力 Permissible cutting torque	F		kgf	2000
	FxR		kg-m	180
	FxL		kg-m	450
淨重 (不含主軸及伺服馬達) Net weight (without spindle and motor)	kg	250		

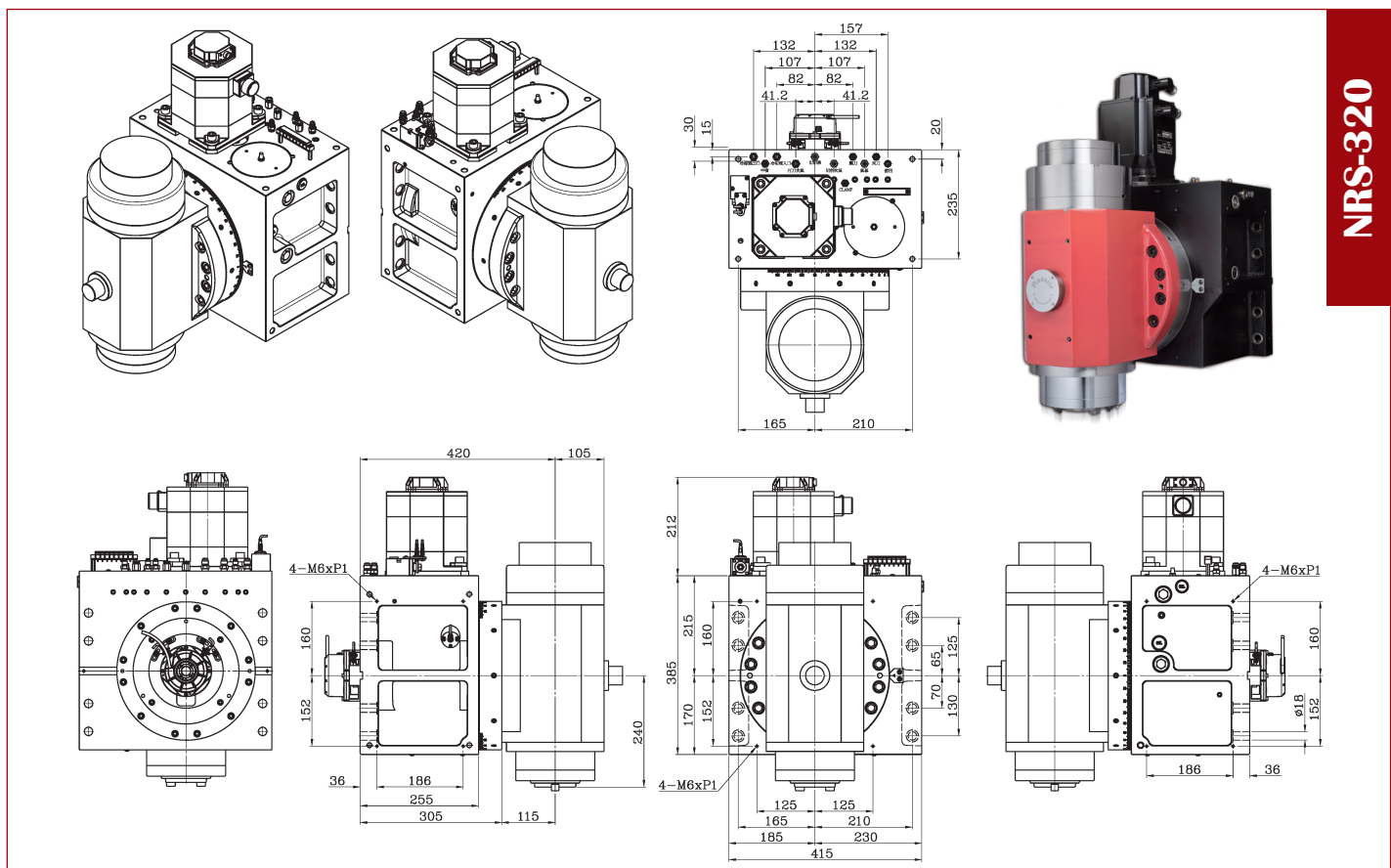

型式 Model	DRS-400	
工作台尺寸 Table size (L x W)	mm	405
傾斜角度 Tilting range		±120°
鎖緊裝置 (油壓) Clamping device (Hydraulic)	kg/cm <sup>2</sup>	35
最小分割角度 Min. indexing degree	degree	0.001°
分割精度 (累積值) Indexing accuracy (accumulative)	arc sec	±4"
重現精度 Repeatability	arc sec	4"
鎖緊扭力 Clamping torque	kg-m	300
鎖緊扭力 (壓力切斷時) Clamping torque (pressure off)	kg-m	30
轉盤驅動方式 (直驅電機) Driven by DD-motor		TMB0291-150
轉盤最高轉速 Max. rotation speed of table	rpm	50
淨重 (不含主軸) Net weight (without spindle)	kg	360

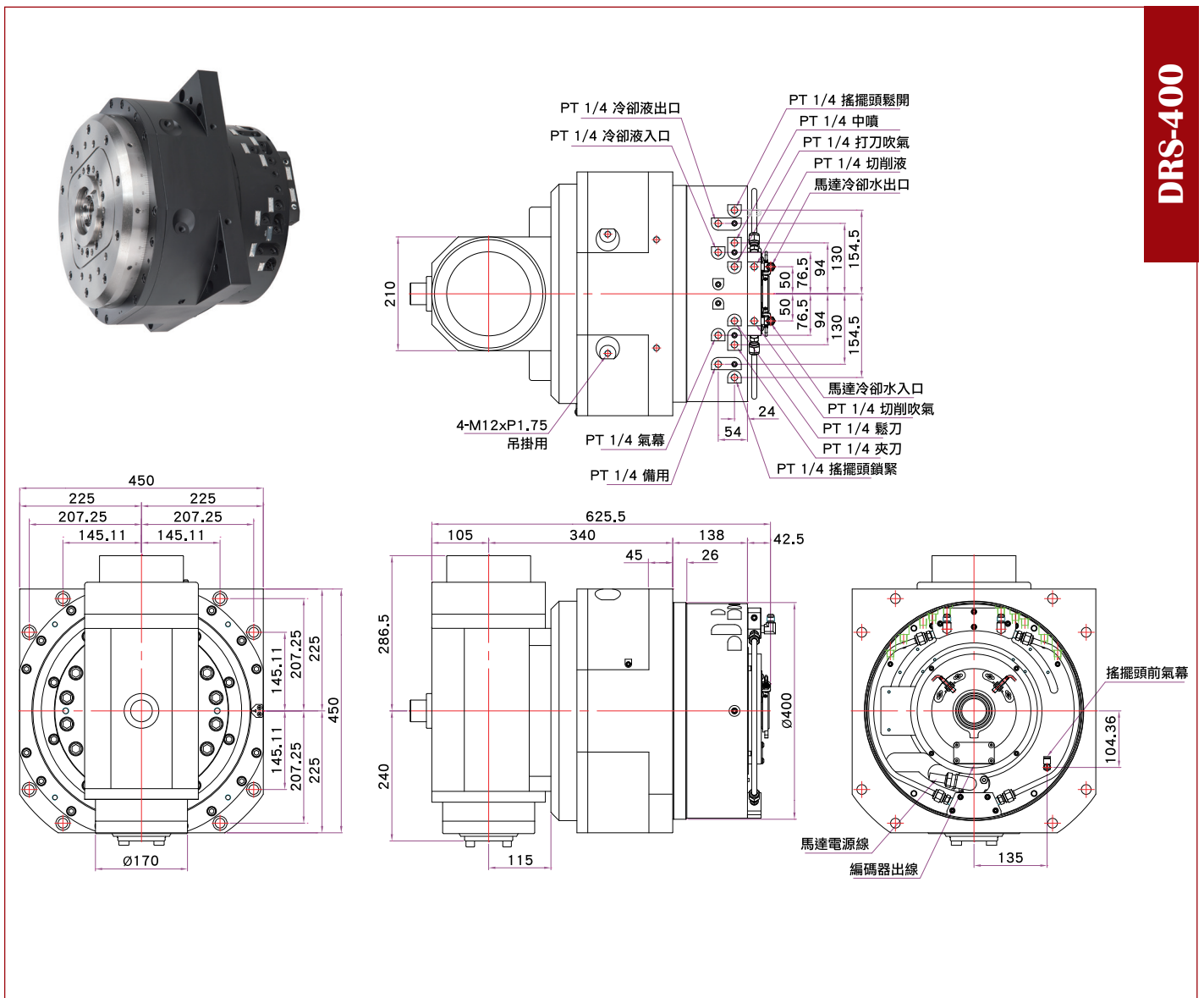

# 直驅旋轉工作台 Direct Drive Rotary Table

型式 Model	DRT-300	
基準中心孔 Center bore	mm	Ø65
中心貫穿孔 Diameter of center through hole		Ø46
中心高度 Center height	mm	150
總高度 Overall height of table	mm	266
驅動方式 Drive		扭力電機直驅 DD Motor
冷卻方式 Cooling		油冷卻 Oil-cooled
瞬間最大扭力 Instantaneous max. torque	Nm	300
持續運轉扭力 Continuous torque	Nm	165
最高轉速 Max. rotation speed	rpm	100
鎖緊扭力 (鎖緊裝置氣壓 5kg/cm <sup>2</sup> ) Clamping force (Pneumatic 5kg/cm <sup>2</sup> )	Nm	350
分割精度 (累積值) Indexing accuracy (accumulative)	arc sec	±20"
重現精度 Repeatability	arc sec	±4"
最小設定單位 Min. indexing degree	degree	0.001°
氣壓切斷時保持扭力 Torque without air pressure	Nm	40
容許切削扭力 (鎖緊狀態) Permissible cutting torque (Clamping)	Nm	130
容許積載荷重 Load Capacity	kg	100
淨重 Net weight	kg	120

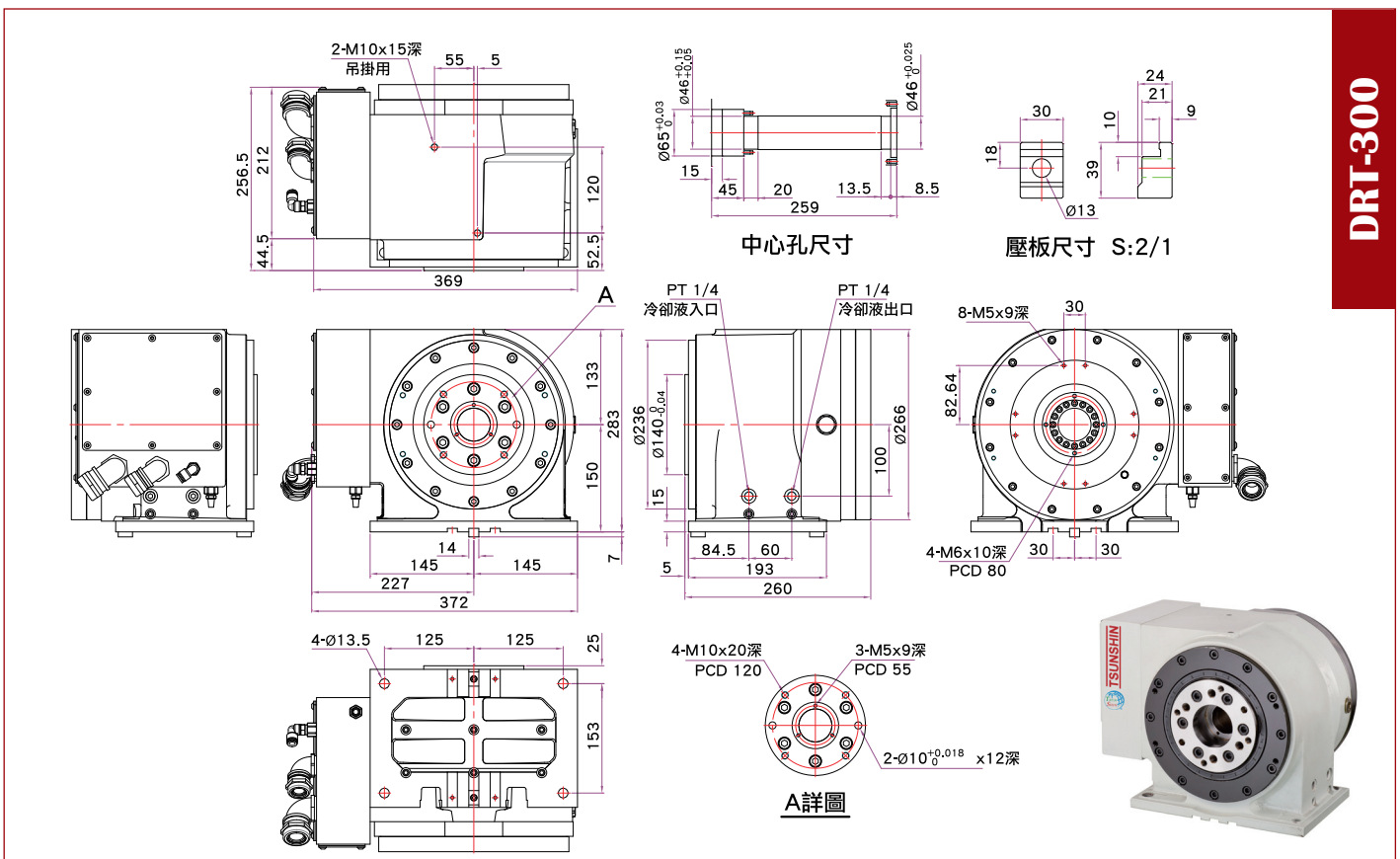

DRT-300